

High Gain, Low Current

Monolithic Amplifier

PSA-8A+

50Ω DC to 4 GHz



CASE STYLE: CA1389

The Big Deal

- Wideband, DC to 4 GHz
- High Gain, 31 dB typ. at 0.1GHz
- Low NF 3.0 dB typ. at 0.1GHz
- Low Current, 36mA typ.

Product Overview

The PSA-8A+ is a HBT based wideband low noise MMIC Amplifier with high gain and low current. This design operates on a single 5V supply, is well matched for 50 Ohms and comes in a SOT-363 package, accommodating dense circuit board layouts.

Key Features

Feature	Advantages
High Gain, 31 dB typ. at 0.1GHz	Enables signal amplification without the need for multiple gain stages.
Low Noise, 3.0 dB typ. at 0.1GHz	Enables lower system noise figure performance. Low NF and High Gain results in lower NF systems
SOT-363 Package	Tiny footprint saves space in dense layouts while providing low inductance, repeatable transitions, and excellent thermal contact to the PCB.

Notes

- A. Performance and quality attributes and conditions not expressly stated in this specification document are intended to be excluded and do not form a part of this specification document.
B. Electrical specifications and performance data contained in this specification document are based on Mini-Circuit's applicable established test performance criteria and measurement instructions.
C. The parts covered by this specification document are subject to Mini-Circuits standard limited warranty and terms and conditions (collectively, "Standard Terms"); Purchasers of this part are entitled to the rights and benefits contained therein. For a full statement of the Standard Terms and the exclusive rights and remedies thereunder, please visit Mini-Circuits' website at www.minicircuits.com/MCLStore/terms.jsp



High Gain, Low Current

Monolithic Amplifier

PSA-8A+

50Ω DC to 4 GHz

Product Features

- Wideband, DC to 4 GHz
- High Gain, 31 dB typ. at 0.1GHz
- Low NF 3.0 dB typ. at 0.1GHz
- Low Current, 36 mA typ.
- Protected by US Patent 6,943,629



Generic photo used for illustration purposes only

CASE STYLE: CA1389

Typical Applications

- Cellular
- PCS
- Communication receivers & Transmitters
- Satellite communication
- Military

+RoHS Compliant

The +Suffix identifies RoHS Compliance. See our web site for RoHS Compliance methodologies and qualifications

General Description

The PSA-8A+ is a HBT based wideband low noise MMIC Amplifier with high gain and low current. This design operates on a single 5V supply, is well matched for 50 Ohms and comes in a SOT-363 package, accommodating dense circuit board layouts.

Simplified schematic and Pad description

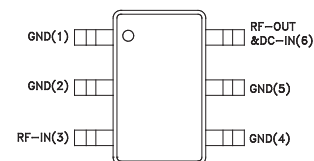
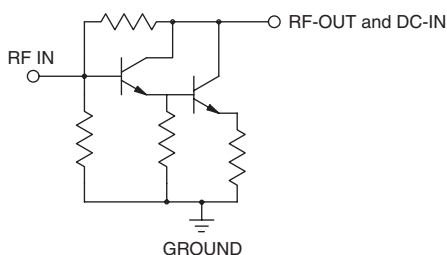

Function	Pin Number	Description (See Application Circuit, Fig. 1)
RF-IN	3	RF input pin (connect to RF-IN via C1)
RF-OUT & DC-IN	6	RF output pin (connected to RF-OUT via blocking cap C2 and supply voltage VDD via RF Choke (CHK) & Resistor R1)
GND	1,2,4,5	Connections to ground

Notes

- A. Performance and quality attributes and conditions not expressly stated in this specification document are intended to be excluded and do not form a part of this specification document.
B. Electrical specifications and performance data contained in this specification document are based on Mini-Circuit's applicable established test performance criteria and measurement instructions.
C. The parts covered by this specification document are subject to Mini-Circuits standard limited warranty and terms and conditions (collectively, "Standard Terms"); Purchasers of this part are entitled to the rights and benefits contained therein. For a full statement of the Standard Terms and the exclusive rights and remedies thereunder, please visit Mini-Circuits' website at www.minicircuits.com/MCLStore/terms.jsp



Electrical Specifications¹ at 25°C, Zo=50Ω

Parameter	Condition (GHz)	Min.	Typ.	Max.	Units
Frequency Range ⁴		DC		4.0	GHz
Gain	0.01	26.7	30.8	36.2	dB
	0.1	26.9	31	36.4	
	1.0	22.1	25.4	29.9	
	2.0	17.5	20.1	23.6	
	3.0	—	15.6	—	
Input Return Loss	0.01		11		dB
	0.1		12		
	1.0		18		
	2.0		18		
	3.0		12		
Output Return Loss	0.01		20		dB
	0.1		19		
	1.0		7		
	2.0		9		
	3.0		16		
P1dB	0.01		12.1		dBm
	0.1		12.8		
	1.0		11.9		
	2.0		9.6		
	3.0		6.5		
OIP3 (Pout = -5dBm/Tone)	0.01		26.1		dBm
	0.1		25.8		
	1.0		23.2		
	2.0		20		
	3.0		16.2		
Noise Figure	0.01		3.1		dB
	0.1		3		
	1.0		3.7		
	2.0		4		
	3.0		4.4		
Supply Voltage (Vs)	DC	4.75	5	5.25	V
Device Operating Current (Is)	DC		36	39	mA
Device Current Variation vs. Voltage ²			0.024		mA/mV
Device Current Variation vs. Temperature ³			7.7		μA/°C
Thermal Resistance, Junction to ground lead			140		°C/W

1. Measured on Mini-Circuits Characterization Test Board TB-PSA-8A+. See Characterization Test Circuit (Fig. 1)

2. Device Current Variation vs. Voltage = (Current at 5.25V - Current at 4.75V)/(5.25V-4.75V)*1000

3. Device Current Variation vs. Temperature = (Current at 85°C - Current at -45°C)/130

4. Guaranteed specifications DC to 4 GHz. Low frequency cut-off determined by external coupling capacitor.

Absolute Maximum Ratings⁵

Parameter	Ratings
Operating Temperature	-40°C to 85°C
Storage Temperature	-65°C to 150°C
Input Power (CW)	13 dBm
Operating Current on Pin 6	65mA

4. Permanent damage may occur if any of these limits are exceeded.
Electrical Maximum rating are not intended for continuous normal operation.

Notes

- A. Performance and quality attributes and conditions not expressly stated in this specification document are intended to be excluded and do not form a part of this specification document.
- B. Electrical specifications and performance data contained in this specification document are based on Mini-Circuit's applicable established test performance criteria and measurement instructions.
- C. The parts covered by this specification document are subject to Mini-Circuits standard limited warranty and terms and conditions (collectively, "Standard Terms"); Purchasers of this part are entitled to the rights and benefits contained therein. For a full statement of the Standard Terms and the exclusive rights and remedies thereunder, please visit Mini-Circuits' website at www.minicircuits.com/MCLStore/terms.jsp



Characterization Test / Application Circuit

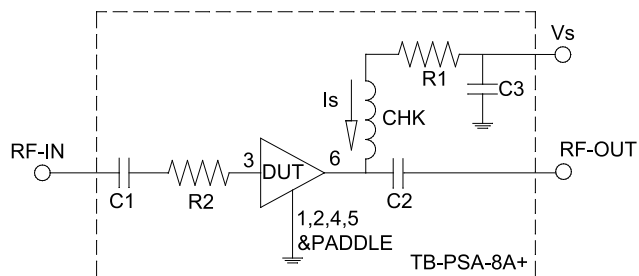

Component	Size	Value	Part Number	Manufacturer
DUT	SOT-363	--	PSA-8A+	MCL
C1,C2	0402	2400pF	GRM155R71H242JA01D	Murata
C3	0603	0.1uF	GCJ188R71H104KA12D	Murata
R1	0805	36.5Ohms	RK73H2ATTD36R5F	KOA
CHK	0.15x0.15	--	TCCH-80+	MCL
R2	402	10Ohms	RK73H1ETTP10R0F	KOA

Fig 1. Block Diagram of Test Circuit used for characterization. (DUT soldered on Mini-Circuits Characterization Test Board TB-PSA-8A+) Gain, Return loss, Output power at 1dB compression (P1 dB), Output IP3 (OIP3) and Noise Figure measured using Agilent's N5242A PNA-X microwave network analyzer.

Conditions:

1. Gain: Pin= -25dBm
2. Output IP3 (OIP3): Two tones, spaced 1 MHz apart, -5 dBm/tone at output.

Product Marking

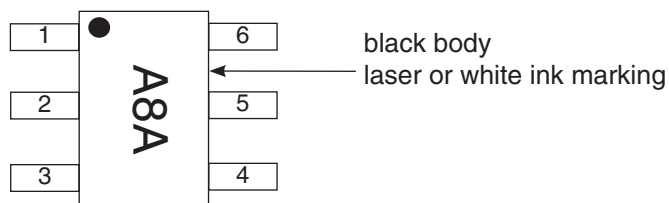

Marking may contain other features or characters for internal lot control

Notes

- A. Performance and quality attributes and conditions not expressly stated in this specification document are intended to be excluded and do not form a part of this specification document.
- B. Electrical specifications and performance data contained in this specification document are based on Mini-Circuit's applicable established test performance criteria and measurement instructions.
- C. The parts covered by this specification document are subject to Mini-Circuits standard limited warranty and terms and conditions (collectively, "Standard Terms"); Purchasers of this part are entitled to the rights and benefits contained therein. For a full statement of the Standard Terms and the exclusive rights and remedies thereunder, please visit Mini-Circuits' website at www.minicircuits.com/MCLStore/terms.jsp



Additional Detailed Technical Information	
<i>additional information is available on our dash board. To access this information click here</i>	
Performance Data	Data Table
	Swept Graphs
	S-Parameter (S2P Files) Data Set (.zip file)
Case Style	CA1389 Plastic molded SOT-363 package, lead finish: Matte-Tin
Tape & Reel Standard quantities available on reel	F101 7" reels with 20, 50, 100, 200, 500, 1K, 2K devices.
Suggested Layout for PCB Design	PL-643
Evaluation Board	TB-PSA-8A+
Environmental Ratings	ENV08T2

ESD Rating

Human Body Model (HBM): Class 1B (500 v to < 1,000 v) in accordance with ANSI/ESD STM 5.1 - 2001

Machine Model (MM): Class M1 (< 100 v) in accordance with ANSI/ESD STM 5.2 - 1999

MSL Test Flow Chart

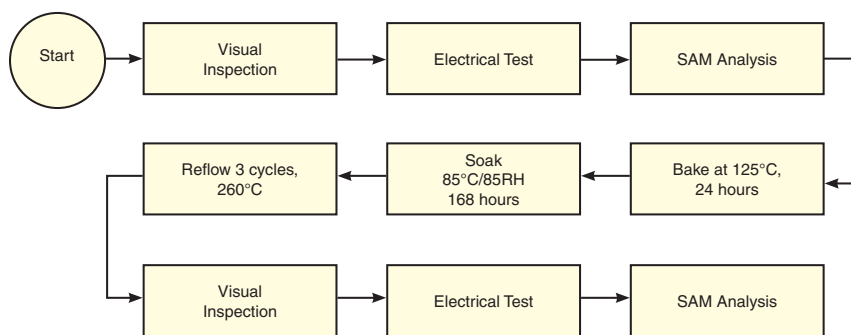

Notes

- A. Performance and quality attributes and conditions not expressly stated in this specification document are intended to be excluded and do not form a part of this specification document.
- B. Electrical specifications and performance data contained in this specification document are based on Mini-Circuit's applicable established test performance criteria and measurement instructions.
- C. The parts covered by this specification document are subject to Mini-Circuits standard limited warranty and terms and conditions (collectively, "Standard Terms"); Purchasers of this part are entitled to the rights and benefits contained therein. For a full statement of the Standard Terms and the exclusive rights and remedies thereunder, please visit Mini-Circuits' website at www.minicircuits.com/MCLStore/terms.jsp



Typical Performance Data

NOTE: Use PDF Bookmarks to view DATA at required conditions

Definitions:

Input Return Loss = -S11 (dB)

Gain(Power Gain) = S21 (dB)

Reverse Isolation = -S12 (dB)

Output Return Loss = -S22 (dB)

TEST CONDITIONS: Vd = 5.00V, Icc = 36mA @ Temperature = +25°C

FREQ (MHz)	Gain (dB)	Isolation (dB)	Input Return Loss (dB)	Output Return Loss (dB)	Stability		IP-3 Output (dBm)	1dB Comp. Output (dBm)	Noise Figure (dB)
					K	Measure			
10	30.89	36.71	10.14	19.19	1.15	0.80	26.04	12.11	3.13
20	31.14	36.48	10.62	21.20	1.13	0.76	25.23	12.58	2.85
30	31.23	36.47	10.83	21.60	1.13	0.75	26.59	12.51	2.88
40	31.27	36.18	10.97	21.16	1.11	0.72	25.65	12.74	2.97
50	31.29	36.11	11.05	21.11	1.11	0.71	26.19	12.80	2.93
60	31.29	36.21	11.17	20.58	1.11	0.72	25.13	12.61	2.91
70	31.29	36.15	11.22	20.06	1.11	0.71	26.12	12.76	2.90
80	31.29	36.21	11.21	19.47	1.11	0.71	25.18	12.86	2.96
90	31.27	36.12	11.36	19.01	1.11	0.71	25.13	12.76	2.95
100	31.26	36.19	11.34	18.60	1.11	0.71	25.59	12.75	2.96
200	30.89	36.01	11.93	14.56	1.10	0.71	24.72	12.77	3.16
250	30.63	35.88	12.27	12.98	1.10	0.70	23.96	12.69	3.24
300	30.34	35.80	12.63	11.75	1.09	0.70	23.96	12.55	3.35
350	30.05	35.60	12.86	10.80	1.08	0.70	24.11	12.65	3.39
400	29.72	35.54	13.24	9.91	1.07	0.70	24.13	12.50	3.44
450	29.39	35.29	13.61	9.23	1.06	0.69	24.15	12.39	3.47
500	29.07	35.00	13.93	8.56	1.04	0.67	23.82	12.62	3.53
550	28.73	34.78	14.29	8.15	1.03	0.66	24.02	12.49	3.59
600	28.39	34.59	14.56	7.71	1.03	0.66	23.79	12.46	3.67
650	28.06	34.35	14.89	7.39	1.02	0.65	23.47	12.23	3.66
700	27.73	34.16	15.11	7.07	1.01	0.64	23.65	12.34	3.69
750	27.41	33.90	15.38	6.88	1.00	0.64	23.32	12.20	3.69
800	27.05	33.61	15.84	6.74	1.00	0.63	23.53	12.44	3.65
850	26.73	33.36	16.06	6.54	1.00	0.63	23.40	12.24	3.67
900	26.41	33.09	16.33	6.46	1.00	0.63	23.26	12.37	3.67
950	26.10	32.98	16.60	6.40	1.01	0.63	23.22	11.97	3.73
1000	25.78	32.71	16.89	6.35	1.01	0.63	23.24	11.95	3.67
1050	25.46	32.52	17.32	6.33	1.02	0.63	23.01	11.92	3.69
1100	25.15	32.31	17.53	6.35	1.03	0.64	22.82	12.03	3.76
1150	24.85	32.12	17.89	6.37	1.04	0.64	22.65	12.05	3.75
1200	24.56	31.79	18.09	6.43	1.04	0.64	22.69	11.72	3.75
1250	24.26	31.69	18.35	6.49	1.06	0.65	22.45	11.72	3.80
1300	23.97	31.44	18.62	6.55	1.07	0.65	22.44	11.74	3.83
1350	23.69	31.17	18.71	6.69	1.08	0.66	22.44	11.72	3.82
1400	23.41	31.02	18.97	6.77	1.10	0.67	22.09	11.27	3.82
1450	23.13	30.75	19.25	6.88	1.10	0.67	21.76	11.31	3.84
1500	22.86	30.59	19.33	7.04	1.12	0.68	21.86	11.12	3.83
1550	22.61	30.45	19.33	7.19	1.14	0.69	21.80	11.02	3.87
1600	22.33	30.21	19.46	7.34	1.15	0.70	21.54	10.84	3.91
1650	22.08	30.06	19.48	7.50	1.17	0.71	21.22	10.58	3.91
1700	21.83	29.92	19.42	7.67	1.19	0.72	21.11	10.37	3.93
1750	21.58	29.72	19.27	7.89	1.21	0.73	20.67	10.34	3.99
1800	21.33	29.52	19.18	8.06	1.22	0.73	20.67	9.97	3.95
1850	21.09	29.36	19.02	8.25	1.24	0.74	20.58	9.93	4.03
1900	20.86	29.28	18.73	8.49	1.27	0.76	20.36	9.77	3.99
1950	20.62	29.05	18.48	8.72	1.28	0.76	20.37	9.56	3.97
2000	20.39	28.93	18.23	8.96	1.30	0.78	19.87	9.37	4.00
2200	19.49	28.31	16.97	10.02	1.37	0.81	19.19	8.86	4.12
2400	18.63	27.86	15.47	11.25	1.45	0.85	18.36	8.09	4.31
2600	17.76	27.49	14.03	12.54	1.53	0.89	18.16	7.57	4.31
2800	16.90	27.13	12.70	13.91	1.62	0.92	17.04	6.97	4.55
3000	16.02	26.90	11.61	14.91	1.72	0.95	16.03	6.28	4.52
3200	15.16	26.71	10.60	15.17	1.82	0.97	15.71	5.90	4.47
3400	14.28	26.63	9.74	14.47	1.95	0.99	14.62	5.13	4.59
3600	13.40	26.55	9.07	13.19	2.07	0.99	13.21	4.54	4.64
3800	12.48	26.52	8.55	11.81	2.21	0.99	12.45	3.61	4.69
4000	11.62	26.53	8.16	10.41	2.34	0.98	11.00	3.11	4.83



Typical Performance Data

Definitions:

Input Return Loss = -S11 (dB)

Gain(Power Gain) = S21 (dB)

Reverse Isolation = -S12 (dB)

Output Return Loss = -S22 (dB)

TEST CONDITIONS: Vd = 4.75V, Icc = 30mA @ Temperature = +25°C

FREQ (MHz)	Gain (dB)	Isolation (dB)	Input Return Loss (dB)	Output Return Loss (dB)	Stability		IP-3 Output (dBm)	1dB Comp. Output (dBm)	Noise Figure (dB)
					K	Measure			
10	29.99	36.44	9.35	17.44	1.19	0.83	24.82	11.16	3.09
20	30.23	36.14	9.70	16.66	1.16	0.78	24.72	11.64	2.83
30	30.31	35.93	9.81	16.18	1.15	0.75	24.93	11.59	2.86
40	30.35	35.95	10.02	16.03	1.15	0.74	24.54	11.72	2.91
50	30.38	35.93	10.02	15.68	1.14	0.74	24.93	11.71	2.90
60	30.39	35.81	10.21	15.55	1.14	0.72	23.94	11.64	2.87
70	30.39	35.88	10.19	15.49	1.14	0.73	24.46	11.80	2.88
80	30.39	35.75	10.19	15.24	1.13	0.72	24.16	11.82	2.92
90	30.37	35.74	10.31	15.14	1.13	0.72	23.94	11.83	2.89
100	30.35	35.83	10.36	14.92	1.14	0.72	24.25	11.82	2.93
200	30.02	35.65	10.88	13.27	1.13	0.72	23.41	11.60	3.13
250	29.78	35.57	11.20	12.44	1.13	0.73	23.21	11.52	3.22
300	29.51	35.28	11.49	11.59	1.11	0.72	22.98	11.38	3.33
350	29.23	35.23	11.77	10.92	1.11	0.72	22.75	11.54	3.38
400	28.92	35.18	12.14	10.27	1.11	0.73	22.74	11.28	3.42
450	28.61	34.91	12.45	9.63	1.10	0.72	22.58	10.95	3.45
500	28.30	34.66	12.81	9.17	1.09	0.71	22.42	11.19	3.48
550	27.99	34.54	13.13	8.76	1.09	0.71	22.61	11.23	3.55
600	27.68	34.24	13.35	8.34	1.07	0.70	22.42	11.19	3.61
650	27.36	33.90	13.72	8.04	1.06	0.69	22.17	10.97	3.62
700	27.04	33.68	13.95	7.73	1.05	0.69	22.35	10.99	3.64
750	26.72	33.61	14.19	7.53	1.06	0.69	22.07	10.99	3.65
800	26.41	33.28	14.49	7.31	1.04	0.68	22.18	11.18	3.63
850	26.10	33.02	14.74	7.11	1.04	0.67	22.11	10.84	3.62
900	25.79	32.87	15.02	6.98	1.04	0.67	22.17	11.25	3.64
950	25.49	32.68	15.26	6.84	1.04	0.67	21.96	10.72	3.74
1000	25.18	32.42	15.60	6.74	1.04	0.67	22.12	10.73	3.65
1050	24.89	32.20	15.85	6.71	1.05	0.67	21.88	10.82	3.65
1100	24.61	31.93	16.01	6.63	1.04	0.67	21.87	10.83	3.71
1150	24.32	31.72	16.36	6.62	1.05	0.67	21.83	10.99	3.73
1200	24.05	31.46	16.52	6.62	1.05	0.67	21.71	10.67	3.68
1250	23.77	31.29	16.69	6.61	1.06	0.67	21.52	10.70	3.74
1300	23.49	31.09	16.89	6.64	1.07	0.67	21.52	10.77	3.76
1350	23.23	30.92	17.05	6.68	1.08	0.68	21.62	10.77	3.76
1400	22.96	30.71	17.20	6.74	1.09	0.68	21.20	10.43	3.78
1450	22.71	30.50	17.30	6.82	1.10	0.69	21.01	10.51	3.78
1500	22.45	30.28	17.39	6.89	1.11	0.69	20.99	10.31	3.77
1550	22.20	30.16	17.47	6.99	1.12	0.70	21.00	10.35	3.82
1600	21.95	29.96	17.54	7.13	1.14	0.71	20.79	9.93	3.86
1650	21.71	29.79	17.52	7.24	1.15	0.72	20.49	9.92	3.85
1700	21.47	29.56	17.48	7.40	1.16	0.72	20.35	9.71	3.86
1750	21.23	29.34	17.34	7.59	1.17	0.73	19.90	9.59	3.89
1800	20.99	29.26	17.25	7.78	1.20	0.74	19.98	9.20	3.89
1850	20.75	29.05	17.10	7.97	1.21	0.75	19.88	9.17	3.94
1900	20.53	28.88	16.85	8.16	1.22	0.76	19.67	9.24	3.92
1950	20.30	28.78	16.75	8.43	1.25	0.77	19.60	8.93	3.97
2000	20.07	28.68	16.54	8.68	1.27	0.79	19.20	8.86	3.94
2200	19.17	28.10	15.43	9.92	1.35	0.83	18.48	8.36	4.04
2400	18.27	27.65	14.23	11.52	1.44	0.88	17.73	7.49	4.07
2600	17.37	27.36	13.04	13.61	1.56	0.92	17.48	7.08	4.25
2800	16.48	27.09	11.93	15.99	1.68	0.96	16.36	6.40	4.35
3000	15.59	26.92	11.03	17.99	1.80	0.99	15.43	5.83	4.37
3200	14.71	26.75	10.17	17.88	1.92	1.01	15.11	5.45	4.39
3400	13.83	26.71	9.51	15.81	2.06	1.01	14.08	4.80	4.45
3600	12.96	26.61	8.95	13.60	2.18	1.01	12.79	4.12	4.53
3800	12.08	26.63	8.52	11.75	2.32	1.00	12.05	3.30	4.58
4000	11.26	26.56	8.14	10.27	2.43	0.98	10.59	2.82	4.69

Typical Performance Data

Definitions:

Input Return Loss = -S11 (dB)

Gain(Power Gain) = S21 (dB)

Reverse Isolation = -S12 (dB)

Output Return Loss = -S22 (dB)

TEST CONDITIONS: Vd = 5.25, Icc = 42mA @ Temperature = +25°C

FREQ	Gain	Isolation	Input Return Loss	Output Return Loss	Stability		IP-3 Output	1dB Comp. Output	Noise Figure
					K	Measure			
(MHz)	(dB)	(dB)	(dB)	(dB)			(dBm)	(dBm)	(dB)
10	31.47	37.24	11.04	18.82	1.15	0.79	27.48	12.76	3.13
20	31.73	36.82	11.66	24.49	1.12	0.74	27.40	13.25	2.85
30	31.82	36.85	11.91	28.07	1.12	0.74	27.10	13.13	2.88
40	31.86	36.71	12.15	28.43	1.12	0.72	26.77	13.50	2.97
50	31.88	36.77	12.20	28.42	1.12	0.72	27.57	13.67	2.93
60	31.88	36.75	12.33	26.83	1.12	0.72	26.60	13.31	2.91
70	31.87	36.61	12.41	25.15	1.11	0.71	27.29	13.53	2.90
80	31.87	36.62	12.41	23.68	1.11	0.71	26.28	13.62	2.96
90	31.85	36.56	12.59	22.58	1.11	0.70	26.38	13.50	2.95
100	31.84	36.54	12.53	21.65	1.10	0.70	26.96	13.38	2.96
200	31.44	36.45	13.18	15.39	1.10	0.70	25.89	13.43	3.16
250	31.16	36.21	13.53	13.48	1.09	0.69	25.51	12.82	3.24
300	30.85	36.11	13.86	12.03	1.08	0.69	25.33	13.36	3.35
350	30.53	36.06	14.11	10.98	1.08	0.69	25.36	13.32	3.39
400	30.17	35.81	14.48	10.03	1.07	0.68	25.24	13.17	3.44
450	29.82	35.66	14.91	9.33	1.07	0.68	25.14	13.24	3.47
500	29.47	35.50	15.23	8.64	1.06	0.67	24.87	13.66	3.53
550	29.11	35.34	15.63	8.20	1.06	0.67	24.88	12.98	3.59
600	28.76	35.00	15.88	7.78	1.04	0.65	24.89	13.07	3.67
650	28.40	34.80	16.14	7.45	1.03	0.65	24.60	13.07	3.66
700	28.05	34.66	16.43	7.15	1.04	0.65	24.54	13.06	3.69
750	27.71	34.38	16.73	6.95	1.03	0.64	24.53	12.90	3.69
800	27.33	34.17	17.16	6.80	1.04	0.64	24.31	13.05	3.65
850	27.00	33.90	17.47	6.64	1.03	0.63	23.99	13.04	3.67
900	26.67	33.68	17.71	6.54	1.04	0.63	24.04	12.98	3.67
950	26.35	33.43	17.97	6.49	1.04	0.63	24.22	12.72	3.72
1000	26.02	33.13	18.26	6.43	1.04	0.63	24.05	12.68	3.67
1050	25.67	33.05	18.74	6.44	1.06	0.64	23.79	12.67	3.69
1100	25.36	32.74	19.04	6.42	1.06	0.64	23.53	12.77	3.76
1150	25.05	32.48	19.36	6.46	1.07	0.64	23.38	12.76	3.75
1200	24.75	32.17	19.50	6.52	1.07	0.64	23.40	12.42	3.75
1250	24.45	32.00	19.87	6.57	1.09	0.65	22.96	12.41	3.80
1300	24.15	31.87	20.15	6.65	1.11	0.66	23.12	12.30	3.83
1350	23.86	31.54	20.28	6.78	1.11	0.66	22.94	12.27	3.82
1400	23.57	31.47	20.58	6.85	1.14	0.67	22.62	11.93	3.82
1450	23.29	31.25	20.83	6.97	1.15	0.68	22.41	11.83	3.84
1500	23.02	31.01	20.87	7.12	1.16	0.69	22.44	11.54	3.83
1550	22.76	30.85	20.92	7.26	1.18	0.69	22.30	11.53	3.87
1600	22.48	30.67	20.92	7.41	1.20	0.70	22.20	11.27	3.91
1650	22.23	30.47	20.92	7.58	1.21	0.71	21.68	11.09	3.91
1700	21.98	30.26	20.84	7.72	1.23	0.72	21.76	10.87	3.93
1750	21.72	30.05	20.65	7.93	1.24	0.73	21.18	10.73	4.02
1800	21.47	29.86	20.44	8.09	1.25	0.73	21.16	10.58	3.95
1850	21.23	29.76	20.28	8.28	1.28	0.74	21.10	10.32	4.03
1900	21.00	29.55	19.94	8.50	1.29	0.75	20.91	10.26	3.99
1950	20.76	29.44	19.60	8.73	1.31	0.76	20.91	9.94	3.97
2000	20.53	29.30	19.26	8.94	1.33	0.77	20.41	9.86	4.00
2200	19.62	28.67	17.79	9.94	1.40	0.81	19.80	9.33	4.12
2400	18.76	28.10	16.09	11.10	1.47	0.84	18.93	8.57	4.31
2600	17.89	27.70	14.51	12.29	1.55	0.88	18.72	7.93	4.31
2800	17.03	27.33	13.11	13.49	1.63	0.91	17.53	7.42	4.55
3000	16.16	27.04	11.93	14.35	1.73	0.94	16.56	6.74	4.59
3200	15.29	26.87	10.82	14.54	1.83	0.96	16.13	6.25	4.47
3400	14.41	26.76	9.96	13.92	1.95	0.98	15.02	5.46	4.59
3600	13.52	26.68	9.21	12.78	2.07	0.98	13.57	4.77	4.64
3800	12.60	26.61	8.67	11.45	2.20	0.98	12.78	4.04	4.69
4000	11.74	26.58	8.24	10.16	2.32	0.97	11.26	3.31	4.83

Typical Performance Data

Definitions:

Input Return Loss = -S11 (dB)

Gain(Power Gain) = S21 (dB)

Reverse Isolation = -S12 (dB)

Output Return Loss = -S22 (dB)

TEST CONDITIONS: Vd = 5.00V, Icc = 35mA @ Temperature = -45°C

FREQ (MHz)	Gain (dB)	Isolation (dB)	Input Return Loss (dB)	Output Return Loss (dB)	Stability		IP-3 Output (dBm)	1dB Comp. Output (dBm)	Noise Figure (dB)
					K	Measure			
10	31.52	37.25	11.07	17.68	1.14	0.78	25.31	12.07	2.70
20	31.79	36.87	11.71	23.50	1.12	0.74	24.85	12.52	2.48
30	31.90	36.92	12.01	27.32	1.12	0.74	25.87	12.55	2.52
40	31.94	36.82	12.23	28.75	1.12	0.72	25.31	12.79	2.57
50	31.97	36.62	12.31	29.27	1.10	0.71	25.85	12.84	2.54
60	31.98	36.75	12.44	27.82	1.11	0.71	24.93	12.60	2.54
70	31.97	36.71	12.49	26.07	1.11	0.71	25.61	12.86	2.53
80	31.98	36.64	12.50	24.39	1.10	0.70	24.70	12.94	2.59
90	31.96	36.55	12.70	23.28	1.10	0.69	24.99	12.84	2.58
100	31.95	36.51	12.63	22.33	1.10	0.69	25.36	12.84	2.61
200	31.60	36.48	13.27	15.68	1.10	0.69	24.53	12.82	2.78
250	31.34	36.34	13.70	13.75	1.09	0.69	24.33	12.74	2.86
300	31.05	36.15	14.20	12.31	1.08	0.68	24.36	12.72	2.96
350	30.76	36.01	14.49	11.24	1.07	0.68	23.56	12.80	3.00
400	30.42	35.89	14.87	10.28	1.07	0.68	24.04	12.63	3.04
450	30.08	35.63	15.31	9.55	1.05	0.67	23.94	12.59	3.05
500	29.75	35.50	15.68	8.79	1.04	0.66	23.86	12.72	3.11
550	29.41	35.24	16.11	8.36	1.04	0.65	23.94	12.62	3.18
600	29.07	35.03	16.46	7.90	1.03	0.64	24.17	12.56	3.23
650	28.73	34.70	16.85	7.55	1.01	0.63	23.30	12.33	3.22
700	28.39	34.56	17.18	7.20	1.01	0.62	23.60	12.54	3.24
750	28.06	34.26	17.54	7.02	1.00	0.62	23.26	12.41	3.23
800	27.70	34.13	18.04	6.84	1.01	0.62	23.62	12.53	3.18
850	27.37	33.96	18.35	6.60	1.01	0.62	23.60	12.32	3.22
900	27.05	33.53	18.60	6.55	1.00	0.61	23.24	12.56	3.20
950	26.74	33.39	18.90	6.47	1.01	0.61	23.64	12.19	3.29
1000	26.42	33.29	19.24	6.37	1.02	0.61	23.33	12.16	3.22
1050	26.09	32.96	19.90	6.37	1.02	0.61	23.11	12.24	3.23
1100	25.78	32.73	20.11	6.35	1.03	0.61	23.15	12.15	3.28
1150	25.48	32.54	20.54	6.36	1.04	0.62	23.20	12.30	3.32
1200	25.19	32.21	20.78	6.43	1.04	0.62	23.12	12.09	3.30
1250	24.89	32.02	21.13	6.48	1.05	0.62	22.77	12.10	3.30
1300	24.61	31.86	21.25	6.52	1.07	0.63	23.13	12.13	3.34
1350	24.32	31.56	21.51	6.62	1.07	0.63	23.00	12.11	3.34
1400	24.04	31.39	21.91	6.70	1.09	0.64	22.48	11.79	3.37
1450	23.76	31.14	22.05	6.81	1.10	0.64	22.49	11.94	3.37
1500	23.49	30.95	21.91	6.93	1.11	0.65	22.33	11.77	3.37
1550	23.24	30.94	21.95	7.10	1.14	0.67	22.40	11.68	3.41
1600	22.97	30.69	21.83	7.24	1.15	0.68	22.32	11.30	3.43
1650	22.72	30.44	21.63	7.36	1.16	0.68	21.91	11.27	3.44
1700	22.47	30.24	21.45	7.53	1.17	0.69	21.76	11.03	3.46
1750	22.22	30.09	21.11	7.71	1.19	0.70	21.48	10.90	3.46
1800	21.98	29.90	20.75	7.86	1.20	0.71	21.34	10.63	3.49
1850	21.74	29.72	20.55	8.04	1.22	0.72	21.41	10.63	3.57
1900	21.51	29.61	20.04	8.27	1.24	0.73	21.23	10.56	3.52
1950	21.28	29.33	19.57	8.43	1.24	0.73	21.27	10.28	3.52
2000	21.04	29.26	19.19	8.64	1.26	0.74	20.72	10.18	3.53
2200	20.15	28.68	17.56	9.59	1.33	0.78	20.14	9.69	3.61
2400	19.30	28.25	15.76	10.66	1.41	0.82	19.41	8.84	3.66
2600	18.47	27.77	14.19	11.77	1.47	0.86	19.24	8.48	3.77
2800	17.65	27.32	12.75	12.98	1.53	0.89	18.12	7.79	3.92
3000	16.81	27.10	11.63	13.76	1.62	0.92	17.28	7.28	3.91
3200	15.97	26.82	10.39	13.97	1.69	0.95	16.95	6.78	3.96
3400	15.11	26.63	9.49	13.23	1.78	0.96	15.92	6.05	4.04
3600	14.24	26.64	8.78	12.13	1.89	0.97	14.48	5.49	4.10
3800	13.34	26.65	8.21	10.80	2.01	0.97	13.85	4.69	4.15
4000	12.48	26.51	7.77	9.55	2.09	0.95	12.25	4.09	4.25

Typical Performance Data

Definitions:

Input Return Loss = -S11 (dB)

Gain(Power Gain) = S21 (dB)

Reverse Isolation = -S12 (dB)

Output Return Loss = -S22 (dB)

TEST CONDITIONS: Vd = 4.75, Icc = 30mA @ Temperature = -45°C

FREQ	Gain	Isolation	Input Return Loss	Output Return Loss	Stability		IP-3 Output	1dB Comp. Output	Noise Figure
					K	Measure			
(MHz)	(dB)	(dB)	(dB)	(dB)	K	Measure	(dBm)	(dBm)	(dB)
10	30.34	36.61	10.06	17.80	1.18	0.82	25.17	10.95	2.75
20	30.63	36.41	10.63	19.55	1.17	0.78	24.70	11.58	2.51
30	30.74	36.38	10.87	19.45	1.16	0.77	25.68	11.56	2.53
40	30.78	36.21	11.09	19.32	1.15	0.75	25.20	11.69	2.56
50	30.82	36.15	11.11	18.91	1.14	0.74	25.65	11.68	2.55
60	30.83	36.11	11.31	18.68	1.14	0.73	24.75	11.53	2.56
70	30.83	36.15	11.32	18.53	1.14	0.73	25.53	11.82	2.56
80	30.84	36.14	11.30	18.13	1.14	0.73	24.55	11.81	2.60
90	30.82	36.09	11.42	17.98	1.14	0.73	24.90	11.82	2.59
100	30.80	36.14	11.50	17.58	1.14	0.73	25.21	11.84	2.60
200	30.50	35.82	12.07	14.76	1.12	0.71	24.55	11.55	2.79
250	30.26	35.67	12.47	13.60	1.12	0.71	24.18	11.34	2.88
300	29.99	35.68	12.78	12.51	1.12	0.72	24.31	11.47	2.99
350	29.71	35.40	13.11	11.62	1.11	0.71	23.50	11.60	3.02
400	29.40	35.17	13.54	10.83	1.10	0.71	24.00	11.34	3.05
450	29.09	35.01	13.86	10.13	1.09	0.70	24.02	11.07	3.09
500	28.78	34.87	14.22	9.58	1.08	0.70	23.83	11.20	3.10
550	28.46	34.62	14.55	9.12	1.08	0.70	23.81	11.25	3.19
600	28.15	34.45	14.80	8.63	1.07	0.69	24.16	11.08	3.25
650	27.83	34.27	15.27	8.27	1.06	0.69	23.31	10.97	3.25
700	27.51	33.99	15.56	7.95	1.06	0.68	23.65	11.10	3.25
750	27.18	33.79	15.92	7.68	1.05	0.67	23.33	10.99	3.26
800	26.87	33.51	16.21	7.44	1.04	0.67	23.63	11.26	3.18
850	26.56	33.33	16.54	7.25	1.05	0.66	23.65	10.81	3.22
900	26.24	33.09	16.87	7.09	1.04	0.66	23.26	11.33	3.24
950	25.94	32.86	17.13	6.93	1.04	0.65	23.66	10.93	3.34
1000	25.64	32.69	17.52	6.81	1.05	0.65	23.40	10.82	3.25
1050	25.34	32.46	17.88	6.74	1.05	0.65	23.17	10.80	3.23
1100	25.06	32.22	18.04	6.67	1.05	0.65	23.14	10.82	3.29
1150	24.77	32.06	18.31	6.63	1.06	0.65	23.21	11.01	3.33
1200	24.49	31.80	18.53	6.61	1.06	0.65	23.11	10.81	3.29
1250	24.22	31.59	18.65	6.61	1.06	0.65	22.81	10.94	3.34
1300	23.94	31.39	18.87	6.60	1.07	0.66	23.12	11.02	3.39
1350	23.68	31.23	19.02	6.65	1.08	0.66	23.01	11.12	3.36
1400	23.41	30.86	19.18	6.71	1.08	0.66	22.50	10.70	3.36
1450	23.17	30.79	19.15	6.76	1.10	0.67	22.50	11.01	3.39
1500	22.91	30.58	19.20	6.81	1.10	0.67	22.34	10.72	3.35
1550	22.66	30.39	19.26	6.92	1.12	0.68	22.38	10.77	3.41
1600	22.42	30.19	19.24	7.04	1.13	0.68	22.31	10.36	3.45
1650	22.18	30.02	19.20	7.13	1.14	0.69	21.92	10.50	3.45
1700	21.93	29.83	19.08	7.27	1.15	0.70	21.76	10.36	3.48
1750	21.71	29.66	18.87	7.44	1.16	0.71	21.47	10.25	3.52
1800	21.47	29.49	18.70	7.62	1.18	0.72	21.36	9.73	3.48
1850	21.23	29.32	18.53	7.79	1.19	0.73	21.42	9.86	3.59
1900	21.02	29.20	18.15	7.97	1.21	0.74	21.23	9.81	3.51
1950	20.79	28.99	17.91	8.22	1.22	0.75	21.27	9.65	3.51
2000	20.55	28.91	17.69	8.47	1.25	0.76	20.71	9.55	3.51
2200	19.68	28.35	16.38	9.55	1.32	0.80	20.14	9.09	3.63
2400	18.80	27.91	14.96	10.94	1.41	0.85	19.41	8.34	3.67
2600	17.92	27.50	13.53	12.77	1.50	0.90	19.25	7.89	3.76
2800	17.06	27.32	12.28	14.78	1.62	0.94	18.12	7.34	3.94
3000	16.20	26.98	11.27	16.42	1.71	0.96	17.27	6.83	3.93
3200	15.33	26.86	10.26	16.32	1.83	0.99	16.95	6.35	3.94
3400	14.46	26.78	9.49	14.71	1.94	0.99	15.92	5.72	4.03
3600	13.58	26.71	8.81	12.61	2.05	0.99	14.48	5.07	4.08
3800	12.69	26.70	8.30	10.80	2.16	0.97	13.86	4.28	4.12
4000	11.84	26.75	7.92	9.40	2.28	0.95	12.25	3.59	4.28

Typical Performance Data

Definitions:

Input Return Loss = -S11 (dB)

Gain(Power Gain) = S21 (dB)

Reverse Isolation = -S12 (dB)

Output Return Loss = -S22 (dB)

TEST CONDITIONS: Vd = 5.25V, Icc = 41mA @ Temperature = -45°C

FREQ (MHz)	Gain (dB)	Isolation (dB)	Input Return Loss (dB)	Output Return Loss (dB)	Stability		IP-3 Output (dBm)	1dB Comp. Output (dBm)	Noise Figure (dB)
					K	Measure			
10	32.04	37.68	11.94	16.28	1.13	0.77	25.01	12.75	2.70
20	32.34	37.40	12.86	22.21	1.12	0.74	26.33	13.35	2.51
30	32.44	37.16	13.23	27.31	1.11	0.71	26.64	13.26	2.53
40	32.49	37.21	13.51	33.07	1.11	0.71	26.30	13.59	2.57
50	32.51	37.19	13.65	35.93	1.11	0.71	26.89	13.69	2.55
60	32.51	36.97	13.75	34.13	1.10	0.69	26.18	13.45	2.52
70	32.52	37.13	13.88	30.37	1.11	0.70	26.99	13.60	2.53
80	32.52	37.04	13.88	27.66	1.10	0.69	26.09	13.76	2.57
90	32.49	37.02	14.08	25.48	1.10	0.69	26.11	13.64	2.58
100	32.48	37.02	13.99	23.86	1.10	0.69	26.85	13.65	2.60
200	32.10	36.81	14.72	16.00	1.09	0.68	25.53	13.74	2.78
250	31.82	36.76	15.22	13.89	1.09	0.68	25.33	13.67	2.85
300	31.52	36.70	15.76	12.37	1.09	0.68	25.56	13.62	2.94
350	31.20	36.46	16.03	11.23	1.08	0.67	24.70	13.68	2.99
400	30.84	36.35	16.50	10.25	1.07	0.67	25.50	13.48	3.03
450	30.48	36.09	16.91	9.51	1.06	0.66	24.52	13.55	3.06
500	30.12	35.85	17.24	8.78	1.05	0.65	25.17	13.70	3.12
550	29.76	35.67	17.73	8.33	1.05	0.64	25.27	13.43	3.16
600	29.39	35.43	18.08	7.89	1.04	0.64	24.96	13.47	3.22
650	29.04	35.21	18.46	7.53	1.04	0.63	24.75	13.46	3.22
700	28.68	35.02	18.82	7.22	1.03	0.62	25.08	13.45	3.24
750	28.33	34.93	19.20	7.02	1.04	0.63	24.82	13.30	3.24
800	27.95	34.59	19.72	6.86	1.04	0.62	24.60	13.46	3.18
850	27.62	34.37	20.04	6.68	1.04	0.62	24.33	13.31	3.24
900	27.28	34.10	20.38	6.60	1.04	0.61	24.15	13.38	3.22
950	26.96	33.82	20.59	6.52	1.04	0.61	24.47	13.03	3.30
1000	26.63	33.56	21.06	6.44	1.04	0.61	24.61	13.09	3.23
1050	26.28	33.35	21.78	6.42	1.05	0.61	24.26	13.07	3.23
1100	25.97	32.99	21.97	6.40	1.05	0.61	24.05	13.08	3.27
1150	25.65	32.94	22.61	6.42	1.07	0.62	23.63	13.20	3.31
1200	25.36	32.57	22.87	6.47	1.07	0.62	23.93	12.98	3.32
1250	25.06	32.46	23.16	6.52	1.09	0.63	23.57	12.87	3.34
1300	24.77	32.18	23.27	6.59	1.09	0.63	23.66	12.86	3.35
1350	24.48	32.01	23.72	6.68	1.11	0.64	23.56	12.83	3.34
1400	24.19	31.80	24.07	6.75	1.12	0.64	23.34	12.52	3.33
1450	23.91	31.57	24.15	6.85	1.13	0.65	23.08	12.52	3.38
1500	23.64	31.34	24.07	6.97	1.15	0.66	23.17	12.26	3.34
1550	23.38	31.10	23.96	7.14	1.16	0.66	22.95	12.26	3.40
1600	23.11	30.96	23.69	7.26	1.18	0.67	22.99	12.00	3.43
1650	22.86	30.76	23.39	7.37	1.19	0.68	22.50	11.73	3.45
1700	22.60	30.59	23.17	7.56	1.20	0.69	22.47	11.60	3.45
1750	22.35	30.38	22.56	7.71	1.22	0.70	21.97	11.57	3.58
1800	22.11	30.24	22.14	7.85	1.23	0.71	22.00	11.20	3.49
1850	21.86	30.10	21.81	8.03	1.25	0.72	21.94	11.08	3.54
1900	21.64	29.85	21.20	8.22	1.26	0.72	21.68	11.01	3.52
1950	21.41	29.70	20.59	8.39	1.27	0.73	21.91	10.83	3.58
2000	21.17	29.53	20.15	8.61	1.29	0.74	21.39	10.73	3.50
2200	20.28	28.94	18.34	9.49	1.35	0.78	20.80	10.22	3.61
2400	19.43	28.34	16.32	10.49	1.41	0.81	19.90	9.37	3.66
2600	18.60	27.96	14.65	11.52	1.48	0.85	19.82	8.80	3.81
2800	17.78	27.55	13.10	12.59	1.55	0.89	18.64	8.20	3.87
3000	16.94	27.18	11.89	13.30	1.62	0.91	17.70	7.58	3.94
3200	16.10	26.98	10.60	13.42	1.70	0.94	17.34	7.19	3.94
3400	15.24	26.89	9.67	12.78	1.80	0.95	16.30	6.44	4.06
3600	14.37	26.73	8.93	11.72	1.89	0.96	14.88	5.67	4.08
3800	13.46	26.64	8.35	10.52	1.99	0.95	14.22	5.07	4.15
4000	12.59	26.65	7.86	9.29	2.09	0.94	12.55	4.35	4.26

Typical Performance Data

Definitions:

Input Return Loss = -S11 (dB)

Gain(Power Gain) = S21 (dB)

Reverse Isolation = -S12 (dB)

Output Return Loss = -S22 (dB)

TEST CONDITIONS: Vd = 5.00V, Icc = 36mA @ Temperature = +85°C

FREQ	Gain	Isolation	Input Return Loss	Output Return Loss	Stability		IP-3 Output	1dB Comp. Output	Noise Figure
					K	Measure			
(MHz)	(dB)	(dB)	(dB)	(dB)			(dBm)	(dBm)	(dB)
10	30.30	36.40	9.43	19.20	1.16	0.83	26.57	12.09	3.46
20	30.54	36.02	9.79	18.97	1.13	0.77	26.96	12.56	3.15
30	30.63	36.10	9.95	18.69	1.14	0.76	26.01	12.47	3.16
40	30.68	35.86	10.08	18.15	1.12	0.74	25.91	12.75	3.23
50	30.70	35.96	10.13	18.04	1.12	0.74	26.06	12.79	3.23
60	30.70	35.84	10.20	17.65	1.12	0.73	25.20	12.59	3.15
70	30.69	35.83	10.24	17.36	1.12	0.73	26.04	12.74	3.19
80	30.68	35.88	10.22	16.87	1.12	0.73	25.42	12.84	3.23
90	30.66	35.93	10.34	16.61	1.12	0.73	25.72	12.74	3.22
100	30.65	35.82	10.29	16.46	1.11	0.73	25.36	12.71	3.25
200	30.28	35.80	10.76	13.64	1.12	0.73	24.50	12.64	3.42
250	30.03	35.52	11.13	12.46	1.10	0.72	24.90	12.56	3.51
300	29.75	35.44	11.55	11.45	1.10	0.72	24.28	12.50	3.64
350	29.48	35.22	11.79	10.62	1.08	0.71	24.20	12.50	3.69
400	29.15	35.08	12.14	9.80	1.07	0.71	23.90	12.35	3.73
450	28.83	34.97	12.47	9.15	1.07	0.70	23.55	12.26	3.76
500	28.52	34.73	12.73	8.49	1.05	0.69	23.56	12.50	3.83
550	28.18	34.49	13.07	8.09	1.04	0.68	23.72	12.23	3.87
600	27.85	34.41	13.34	7.68	1.04	0.68	23.80	12.33	3.97
650	27.53	34.05	13.58	7.37	1.02	0.67	23.16	12.21	3.95
700	27.20	33.97	13.83	7.06	1.02	0.67	23.31	12.20	3.98
750	26.87	33.66	14.06	6.88	1.01	0.66	23.32	12.06	3.99
800	26.52	33.40	14.39	6.70	1.01	0.66	23.40	12.18	3.94
850	26.20	33.16	14.58	6.54	1.01	0.65	22.91	12.00	3.98
900	25.88	32.95	14.86	6.47	1.01	0.65	22.81	12.11	3.97
950	25.57	32.56	15.03	6.42	1.00	0.65	23.03	11.72	4.02
1000	25.25	32.44	15.34	6.35	1.01	0.65	22.74	11.80	3.99
1050	24.93	32.25	15.72	6.35	1.03	0.65	22.65	11.79	3.99
1100	24.62	31.95	15.83	6.34	1.02	0.65	22.46	11.78	4.06
1150	24.31	31.80	16.17	6.37	1.04	0.66	22.26	11.78	4.11
1200	24.02	31.48	16.39	6.44	1.04	0.66	22.19	11.44	4.06
1250	23.72	31.30	16.57	6.53	1.06	0.67	21.98	11.43	4.12
1300	23.44	31.07	16.77	6.60	1.07	0.67	21.99	11.35	4.13
1350	23.16	30.97	16.93	6.74	1.10	0.69	21.62	11.32	4.13
1400	22.87	30.67	17.21	6.85	1.10	0.69	21.46	10.98	4.12
1450	22.60	30.47	17.44	6.97	1.12	0.70	21.18	10.89	4.14
1500	22.33	30.34	17.54	7.14	1.14	0.71	21.25	10.69	4.14
1550	22.07	30.13	17.66	7.32	1.16	0.72	21.04	10.58	4.19
1600	21.80	29.98	17.73	7.47	1.18	0.72	20.96	10.30	4.23
1650	21.54	29.78	17.82	7.62	1.19	0.73	20.46	10.02	4.25
1700	21.29	29.56	17.92	7.82	1.21	0.74	20.32	9.81	4.24
1750	21.04	29.48	17.86	8.06	1.24	0.75	19.97	9.78	4.30
1800	20.79	29.28	17.79	8.25	1.25	0.76	19.93	9.51	4.27
1850	20.55	29.08	17.75	8.47	1.26	0.77	19.88	9.35	4.39
1900	20.31	28.97	17.63	8.73	1.29	0.78	19.61	9.19	4.31
1950	20.08	28.77	17.37	8.94	1.30	0.79	19.59	8.97	4.29
2000	19.84	28.62	17.18	9.21	1.32	0.80	19.03	8.78	4.32
2200	18.93	28.08	16.32	10.42	1.41	0.84	18.38	8.37	4.44
2400	18.05	27.67	15.01	11.80	1.50	0.88	17.53	7.48	4.50
2600	17.17	27.24	13.75	13.32	1.59	0.91	17.23	7.03	4.60
2800	16.28	26.95	12.54	15.05	1.69	0.95	16.12	6.31	4.76
3000	15.37	26.74	11.60	16.39	1.82	0.97	15.11	5.60	4.82
3200	14.46	26.63	10.58	16.67	1.95	1.00	14.73	5.21	4.82
3400	13.54	26.54	9.83	15.72	2.09	1.01	13.63	4.51	4.89
3600	12.63	26.52	9.22	14.20	2.25	1.01	12.17	3.93	4.99
3800	11.71	26.57	8.78	12.62	2.44	1.01	11.36	2.98	5.06
4000	10.86	26.62	8.38	11.15	2.60	1.00	9.98	2.48	5.21

Typical Performance Data

Definitions:

Input Return Loss = -S11 (dB)

Gain(Power Gain) = S21 (dB)

Reverse Isolation = -S12 (dB)

Output Return Loss = -S22 (dB)

TEST CONDITIONS: Vd = 4.75V, Icc = 30mA @ Temperature = +85°C

FREQ (MHz)	Gain (dB)	Isolation (dB)	Input Return Loss (dB)	Output Return Loss (dB)	Stability		IP-3 Output (dBm)	1dB Comp. Output (dBm)	Noise Figure (dB)
					K	Measure			
10	29.70	36.30	9.03	17.06	1.20	0.84	22.95	11.16	3.51
20	29.96	35.94	9.34	15.96	1.16	0.78	24.48	11.69	3.16
30	30.04	35.93	9.46	15.42	1.16	0.77	24.87	11.65	3.19
40	30.08	35.80	9.63	15.21	1.15	0.75	24.84	11.80	3.25
50	30.11	35.78	9.65	14.96	1.15	0.74	25.34	11.80	3.24
60	30.12	35.75	9.81	14.75	1.15	0.73	24.36	11.60	3.18
70	30.12	35.77	9.81	14.67	1.15	0.74	24.40	11.86	3.19
80	30.11	35.64	9.77	14.45	1.14	0.73	24.26	11.89	3.25
90	30.09	35.68	9.89	14.34	1.14	0.73	24.37	11.81	3.22
100	30.07	35.65	9.94	14.16	1.14	0.72	24.74	11.78	3.22
200	29.74	35.51	10.37	12.75	1.13	0.73	23.58	11.66	3.43
250	29.50	35.31	10.72	12.12	1.13	0.73	23.24	11.49	3.52
300	29.23	35.33	10.99	11.38	1.13	0.74	23.07	11.45	3.64
350	28.97	35.06	11.27	10.78	1.11	0.73	22.74	11.49	3.70
400	28.67	34.88	11.69	10.15	1.11	0.73	22.61	11.25	3.76
450	28.36	34.72	11.99	9.57	1.10	0.72	22.39	11.03	3.77
500	28.06	34.55	12.33	9.15	1.09	0.72	22.56	11.27	3.82
550	27.74	34.37	12.60	8.73	1.09	0.72	22.54	11.20	3.88
600	27.44	34.18	12.84	8.30	1.08	0.71	22.33	11.05	3.95
650	27.13	33.86	13.22	8.00	1.06	0.70	22.19	10.83	3.97
700	26.81	33.68	13.42	7.74	1.06	0.70	22.09	10.96	3.98
750	26.49	33.43	13.72	7.50	1.06	0.69	21.92	10.85	4.01
800	26.19	33.19	13.93	7.29	1.05	0.69	22.15	11.15	3.94
850	25.87	32.95	14.23	7.11	1.05	0.68	21.90	10.81	3.98
900	25.56	32.68	14.44	6.98	1.04	0.68	21.87	11.11	4.00
950	25.26	32.49	14.72	6.83	1.04	0.68	21.85	10.58	4.07
1000	24.96	32.30	15.01	6.74	1.05	0.68	21.88	10.59	4.00
1050	24.66	32.06	15.35	6.69	1.05	0.67	21.63	10.57	4.01
1100	24.38	31.74	15.45	6.61	1.04	0.67	21.58	10.69	4.06
1150	24.09	31.61	15.71	6.59	1.05	0.68	21.56	10.61	4.06
1200	23.81	31.38	15.94	6.56	1.06	0.67	21.45	10.39	4.08
1250	23.53	31.19	16.10	6.62	1.07	0.68	21.26	10.53	4.09
1300	23.26	30.95	16.25	6.62	1.07	0.68	21.16	10.47	4.14
1350	23.00	30.73	16.44	6.67	1.08	0.68	21.08	10.47	4.14
1400	22.73	30.53	16.65	6.75	1.09	0.69	20.70	10.12	4.12
1450	22.48	30.34	16.64	6.82	1.10	0.70	20.46	10.19	4.14
1500	22.22	30.20	16.81	6.90	1.11	0.70	20.44	9.87	4.16
1550	21.97	29.93	16.89	7.01	1.12	0.71	20.42	9.78	4.19
1600	21.73	29.81	16.93	7.15	1.14	0.72	20.14	9.59	4.22
1650	21.49	29.57	16.91	7.27	1.15	0.72	19.80	9.45	4.22
1700	21.24	29.44	16.89	7.43	1.17	0.73	19.69	9.14	4.24
1750	21.00	29.27	16.73	7.63	1.18	0.74	19.24	9.00	4.30
1800	20.76	29.09	16.69	7.82	1.20	0.75	19.30	8.73	4.28
1850	20.52	28.96	16.63	8.02	1.22	0.76	19.15	8.68	4.38
1900	20.30	28.79	16.35	8.24	1.23	0.77	18.98	8.65	4.28
1950	20.07	28.67	16.23	8.51	1.26	0.78	18.85	8.31	4.32
2000	19.83	28.49	16.01	8.78	1.27	0.80	18.35	8.14	4.31
2200	18.92	27.97	15.15	10.02	1.36	0.84	17.71	7.74	4.40
2400	18.02	27.57	14.05	11.67	1.46	0.89	16.93	6.84	4.46
2600	17.12	27.31	12.96	13.91	1.59	0.93	16.58	6.41	4.56
2800	16.23	27.03	11.87	16.67	1.71	0.97	15.47	5.82	4.74
3000	15.32	26.82	11.01	19.05	1.84	1.00	14.49	5.32	4.79
3200	14.42	26.70	10.20	18.62	1.97	1.01	14.12	4.84	4.79
3400	13.53	26.64	9.52	16.28	2.11	1.02	13.05	4.04	4.89
3600	12.64	26.60	8.98	13.86	2.25	1.01	11.78	3.35	4.96
3800	11.76	26.59	8.57	11.96	2.40	1.00	11.00	2.74	5.01
4000	10.95	26.58	8.24	10.52	2.53	0.99	9.70	2.15	5.16



Typical Performance Data

Definitions:

Input Return Loss = -S11 (dB)

Gain(Power Gain) = S21 (dB)

Reverse Isolation = -S12 (dB)

Output Return Loss = -S22 (dB)

TEST CONDITIONS: Vd = 5.25V, Icc = 42mA @ Temperature = +85°C

FREQ	Gain	Isolation	Input Return Loss	Output Return Loss	Stability		IP-3 Output	1dB Comp. Output	Noise Figure
					K	Measure			
(MHz)	(dB)	(dB)	(dB)	(dB)			(dBm)	(dBm)	(dB)
10	30.94	36.82	10.31	20.17	1.15	0.81	28.51	12.47	3.46
20	31.19	36.39	10.78	22.85	1.12	0.76	26.07	12.98	3.15
30	31.29	36.25	10.95	23.43	1.11	0.74	26.32	12.85	3.15
40	31.33	36.38	11.14	22.87	1.12	0.74	26.32	13.36	3.24
50	31.34	36.30	11.19	22.59	1.11	0.73	27.40	13.48	3.22
60	31.35	36.33	11.29	21.85	1.12	0.73	25.55	13.18	3.16
70	31.34	36.36	11.35	21.12	1.12	0.73	26.76	13.29	3.16
80	31.33	36.39	11.31	20.33	1.12	0.73	26.03	13.37	3.23
90	31.31	36.22	11.45	19.70	1.11	0.72	26.53	13.33	3.21
100	31.29	36.17	11.38	19.26	1.11	0.71	26.74	13.09	3.22
200	30.89	36.17	11.87	14.74	1.11	0.72	25.69	13.15	3.42
250	30.61	35.97	12.25	13.20	1.10	0.71	25.29	12.34	3.50
300	30.32	35.80	12.68	11.95	1.09	0.71	25.31	12.46	3.62
350	30.02	35.66	12.94	10.95	1.08	0.71	25.36	12.53	3.70
400	29.67	35.51	13.29	10.06	1.08	0.70	25.36	12.54	3.71
450	29.32	35.48	13.61	9.37	1.08	0.70	24.87	12.51	3.77
500	28.98	35.33	13.91	8.64	1.07	0.70	24.91	13.07	3.80
550	28.63	35.09	14.24	8.19	1.06	0.69	24.67	12.37	3.88
600	28.27	34.82	14.49	7.78	1.05	0.68	24.42	12.58	3.96
650	27.92	34.53	14.77	7.45	1.04	0.67	24.48	12.63	3.93
700	27.57	34.26	15.05	7.15	1.03	0.66	24.30	12.58	3.98
750	27.23	34.22	15.28	6.98	1.04	0.67	24.46	12.41	3.97
800	26.85	33.94	15.65	6.83	1.05	0.66	23.90	12.41	3.94
850	26.53	33.67	15.87	6.63	1.04	0.65	23.74	12.62	3.96
900	26.19	33.45	16.13	6.57	1.04	0.66	23.44	12.55	3.98
950	25.86	33.17	16.33	6.52	1.04	0.65	23.74	12.31	3.98
1000	25.53	33.01	16.65	6.45	1.05	0.66	23.77	12.19	3.96
1050	25.19	32.72	17.06	6.44	1.06	0.66	23.44	12.39	3.98
1100	24.88	32.55	17.22	6.43	1.07	0.66	23.03	12.39	4.07
1150	24.56	32.22	17.54	6.48	1.07	0.66	22.91	12.27	4.08
1200	24.26	32.05	17.77	6.55	1.09	0.67	22.84	12.02	4.08
1250	23.96	31.73	18.00	6.62	1.09	0.67	22.45	12.01	4.10
1300	23.66	31.53	18.21	6.68	1.11	0.67	22.40	11.89	4.13
1350	23.37	31.35	18.41	6.84	1.13	0.68	22.32	11.75	4.11
1400	23.08	31.12	18.75	6.94	1.14	0.69	22.14	11.51	4.11
1450	22.80	30.92	18.83	7.07	1.16	0.70	21.79	11.41	4.16
1500	22.53	30.71	18.92	7.21	1.17	0.71	21.89	11.21	4.12
1550	22.26	30.58	19.03	7.40	1.20	0.72	21.79	10.98	4.18
1600	21.99	30.40	19.08	7.56	1.22	0.73	21.50	10.71	4.23
1650	21.74	30.19	19.12	7.70	1.23	0.73	21.05	10.52	4.24
1700	21.48	30.00	19.18	7.89	1.25	0.74	20.91	10.32	4.24
1750	21.22	29.82	19.15	8.11	1.27	0.75	20.47	10.27	4.34
1800	20.97	29.65	18.97	8.28	1.28	0.76	20.56	10.01	4.28
1850	20.72	29.46	18.94	8.51	1.30	0.77	20.44	9.74	4.41
1900	20.49	29.35	18.73	8.76	1.33	0.78	20.10	9.69	4.30
1950	20.26	29.18	18.43	8.98	1.34	0.79	20.27	9.46	4.32
2000	20.02	29.02	18.17	9.22	1.36	0.80	19.60	9.38	4.32
2200	19.11	28.44	17.19	10.33	1.44	0.83	19.05	8.74	4.41
2400	18.23	27.95	15.64	11.64	1.52	0.87	18.09	7.85	4.49
2600	17.35	27.56	14.27	13.07	1.62	0.90	17.85	7.41	4.55
2800	16.47	27.18	12.94	14.65	1.71	0.94	16.68	6.67	4.74
3000	15.56	26.93	11.88	15.73	1.82	0.96	15.69	6.07	4.88
3200	14.64	26.80	10.76	15.89	1.95	0.99	15.24	5.46	4.86
3400	13.72	26.75	9.96	15.01	2.10	1.00	14.08	4.87	4.96
3600	12.81	26.70	9.33	13.59	2.25	1.00	12.62	4.05	5.01
3800	11.89	26.69	8.87	12.18	2.42	1.00	11.85	3.32	5.08
4000	11.02	26.72	8.47	10.81	2.58	0.99	10.45	2.70	5.23

Typical Performance Curves

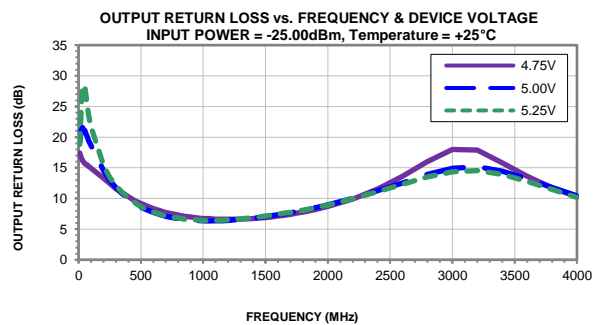
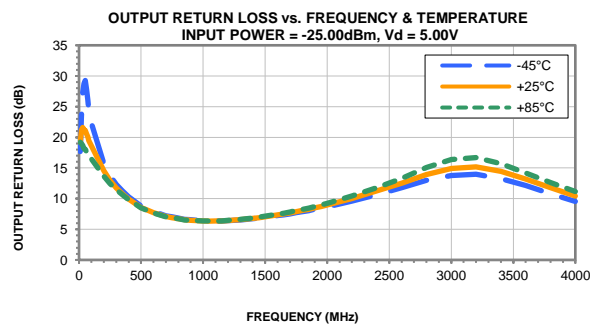
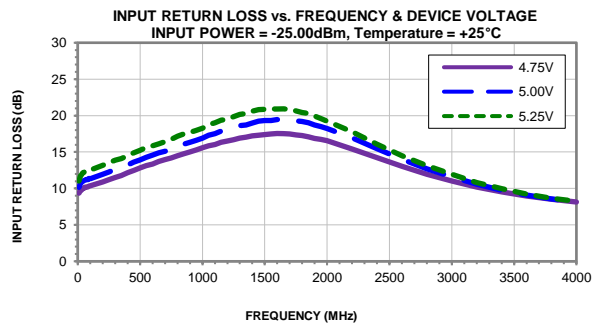
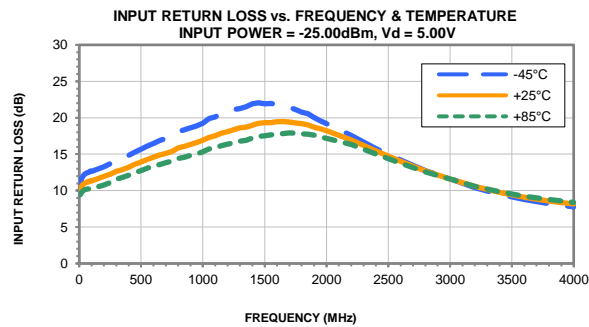
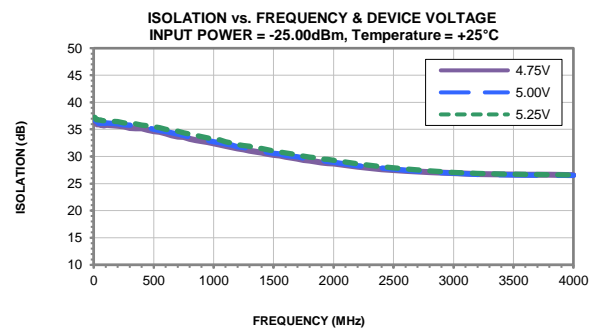
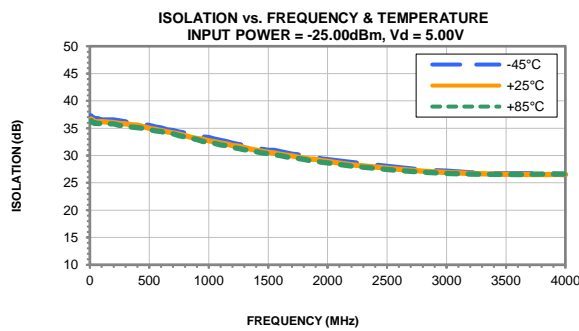
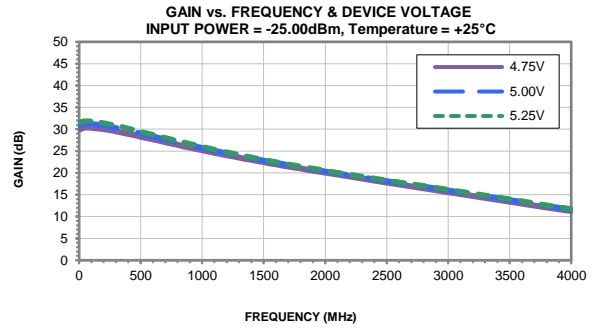
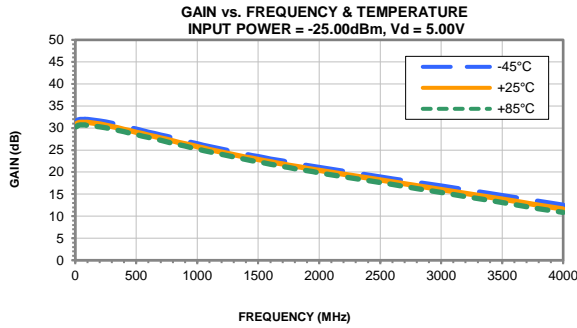

Typical Performance Curves

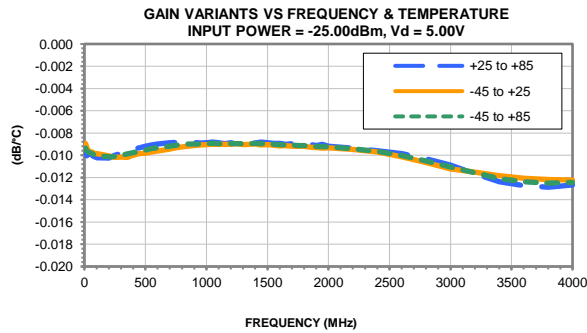
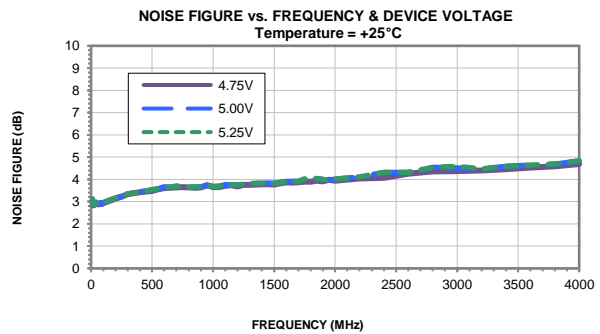
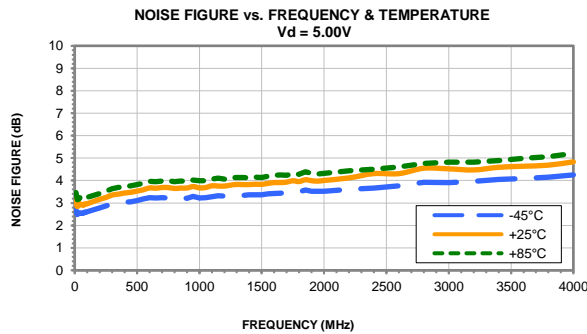
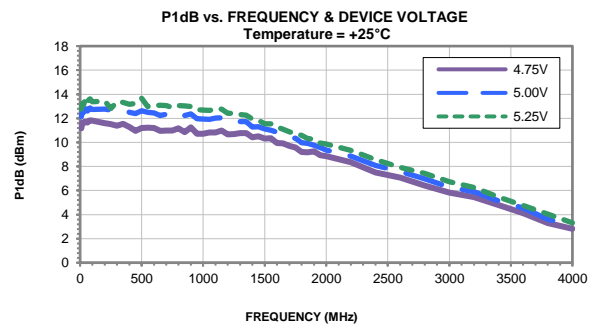
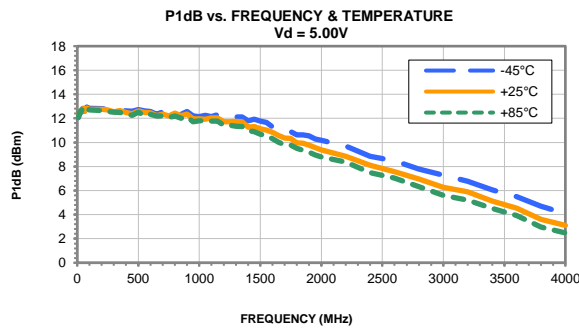
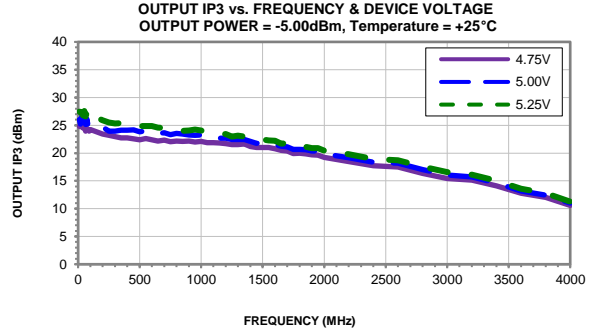
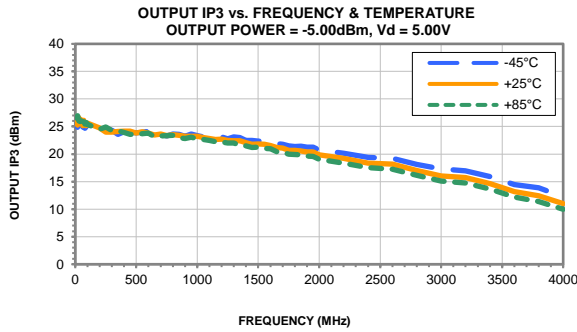

Outline Dimensions

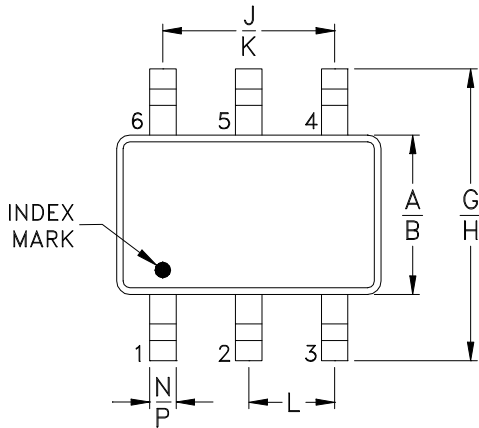

PCB Land Pattern

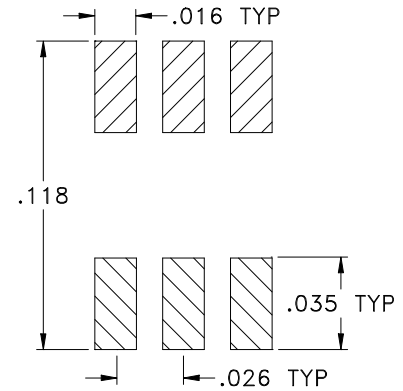

Suggested Layout,
Tolerance to be within $\pm .002$

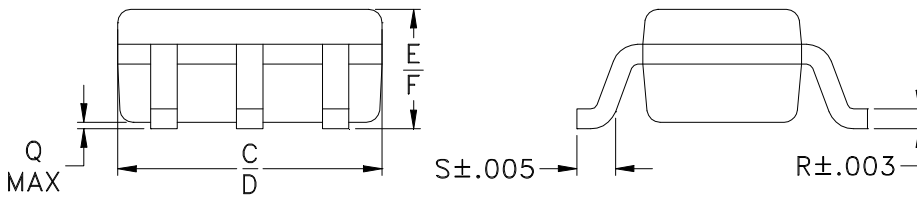

CASE #	A	B	C	D	E	F	G	H	J	K
CA1389	.045 (1.15)	.053 (1.35)	.073 (1.85)	.089 (2.25)	.031 (0.80)	.039 (1.00)	.079 (2.00)	.091 (2.30)	.051 (1.30)	.051 (1.30)

CASE #	L	M	N	P	Q	R	S	T	WT. GRAM
CA1389	.026 (0.65)	-	.006 (0.15)	.012 (0.30)	.004 (0.09)	.007 (0.165)	.012 (0.31)	-	.010

Dimensions are in inches (mm). Tolerances: 2Pl. $\pm .01$; 3Pl. $\pm .005$

Notes:

- Case material: Plastic.
- Termination finish:
For RoHS Case Styles: Matte Tin plate.
- Primary dimensions are in millimeters.



INTERNET <http://www.minicircuits.com>

P.O. Box 350166, Brooklyn, New York 11235-0003 (718) 934-4500 Fax (718) 332-4661

Distribution Centers NORTH AMERICA 800-654-7949 • 417-335-5935 • Fax 417-335-5945 • EUROPE 44-1252-832600 • Fax 44-1252-837010

Mini-Circuits ISO 9001 & ISO 14001 Certified

Tape & Reel Packaging TR-F101

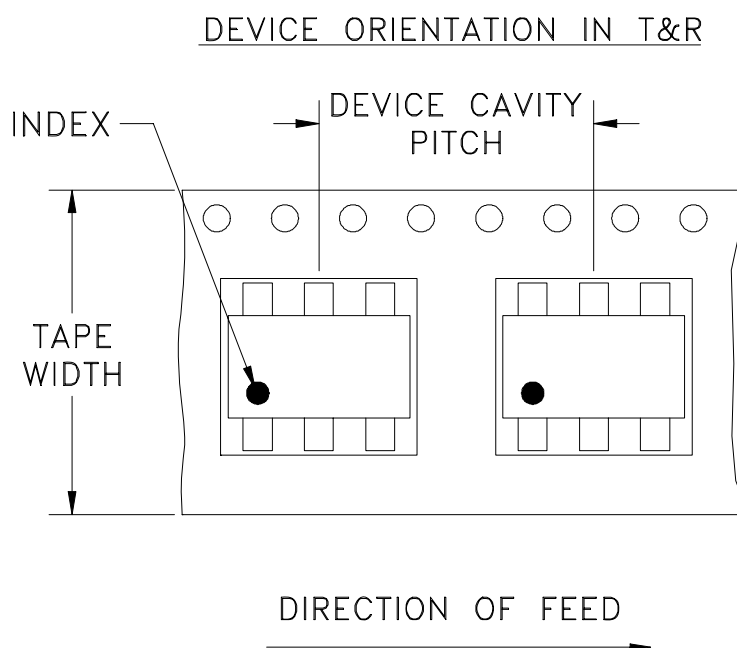

Tape Width, mm	Device Cavity Pitch, mm	Reel Size, inches	Devices per Reel	
8	4	7	Small quantity standards (see note)	20
				50
				100
				200
				500
				1000
		7	Standard	2000

Note: Please Consult individual model data sheet to determine device per reel availability.

Mini-Circuits carrier tape materials provide protection from ESD (Electro-Static Discharge) during handling and transportation. Tapes are static dissipative and comply with industry standards EIA-481/EIA-541.

Go to: www.minicircuits.com/pages/pdfs/tape.pdf



INTERNET <http://www.minicircuits.com>

P.O. Box 350166, Brooklyn, New York 11235-0003 (718) 934-4500 Fax (718) 332-4661

Distribution Centers NORTH AMERICA 800-654-7949 • 417-335-5935 • Fax 417-335-5945 • EUROPE 44-1252-832600 • Fax 44-1252-837010

Mini-Circuits ISO 9001 & ISO 14001 Certified

THIRD ANGLE PROJECTION

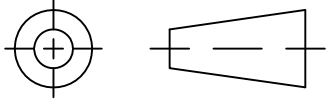

REVISIONS

REV	ECN No.	DESCRIPTION	DATE	DR	AUTH
OR	M175905	NEW RELEASE	08/19/19	ITG	GH

SUGGESTED MOUNTING CONFIGURATION FOR CA1389 CASE STYLE

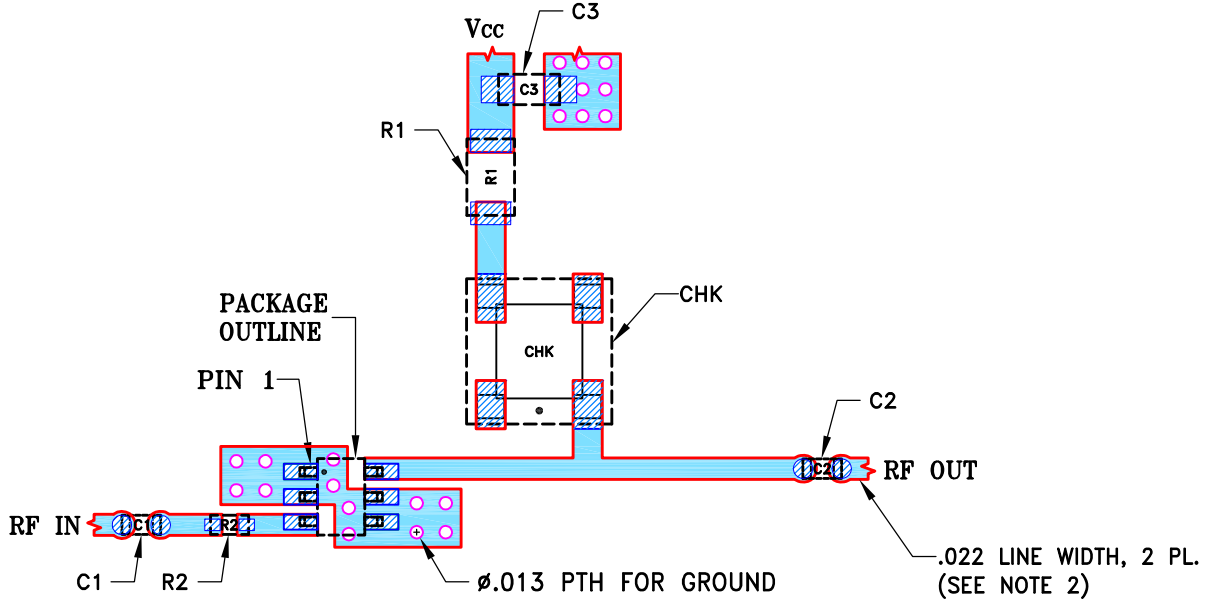

STACK-UP DIAGRAM

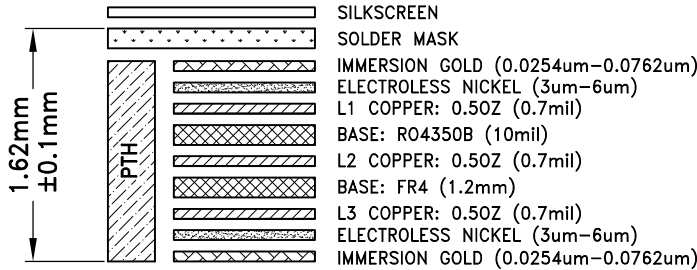

COMPONENT	SIZE
C1,C2	0402
C3	0603
R1	0805
CHK	.150 SQ.
R2	0402

1. TOTAL FINISHED THICKNESS 0.064" ± 10%.
2. PTH HOLES PRESENT FROM COPPER LAYER 1 TO 3.

NOTES:

1. PCB IS MULTILAYER PCB, SEE STACK-UP DIAGRAM.
2. LINE WIDTH IS SHOWN FOR ROGERS R04350B WITH DIELECTRIC THICKNESS .010"±.001"; COPPER: 1/2 OZ. FOR OTHER MATERIALS LINE WIDTH MAY NEED TO BE MODIFIED.
3. CHIP COMPONENT FOOT PRINTS SHOWN FOR REFERENCE. FOR COMPONENT VALUES REFER TO TB-PSA-8A+.
4. COPPER LAYERS L2 & L3 OF THE PCB ARE CONTINUOUS GROUND PLANES.



DENOTES PCB COPPER LAYOUT WITH SMOBC (SOLDER MASK OVER BARE COPPER)

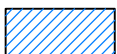

DENOTES COPPER LAND PATTERN FREE OF SOLDER MASK

UNLESS OTHERWISE SPECIFIED	INITIALS	DATE
DIMENSIONS ARE IN INCHES	ITG	08/15/19
TOLERANCES ON:	GF	08/16/19
2 PL DECIMALS ±	GH	08/19/19
3 PL DECIMALS ± .005		
ANGLES ±		
FRACTIONS ±		



Mini-Circuits®

13 Neptune Avenue
Brooklyn NY 11235

PL, CA1389, TB-PSA-8A+

SIZE	CODE IDENT	DRAWING NO:	REV:
A	15542	98-PL-643	OR
FILE:	98PL643	SCALE:	5:1
		SHEET:	1 OF 1

THIS DOCUMENT AND ITS CONTENTS ARE THE PROPERTY OF MINI-CIRCUITS. EXCEPT FOR USE EXPRESSLY GRANTED, IN WRITING, TO ITS VENDORS, VENDEE AND THE UNITED STATES GOVERNMENT, MINI-CIRCUITS RESERVES ALL PROPRIETARY DESIGN, USE, MANUFACTURING AND REPRODUCTION RIGHTS THERETO. THESE CONTENTS SHALL NOT BE USED, DUPLICATED OR DISCLOSED TO ANY OUTSIDE PARTY, IN WHOLE OR IN PART, WITHOUT WRITTEN PERMISSION OF MINI-CIRCUITS.

Evaluation Board and Circuit

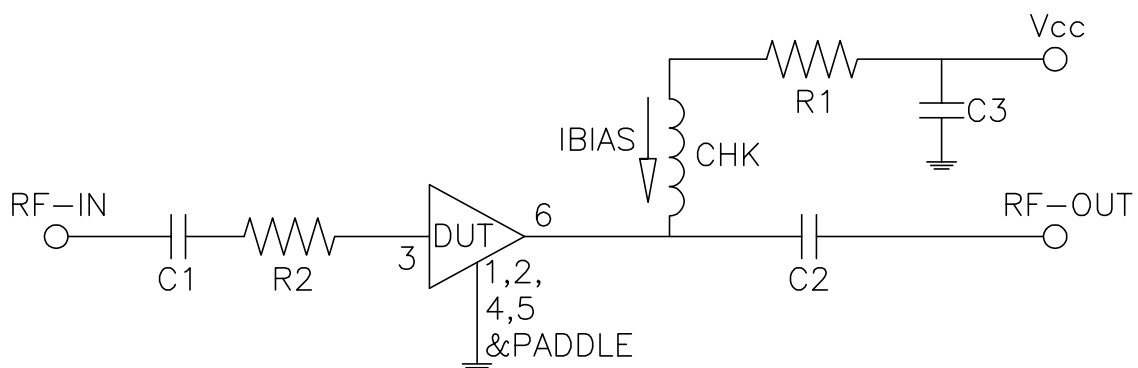
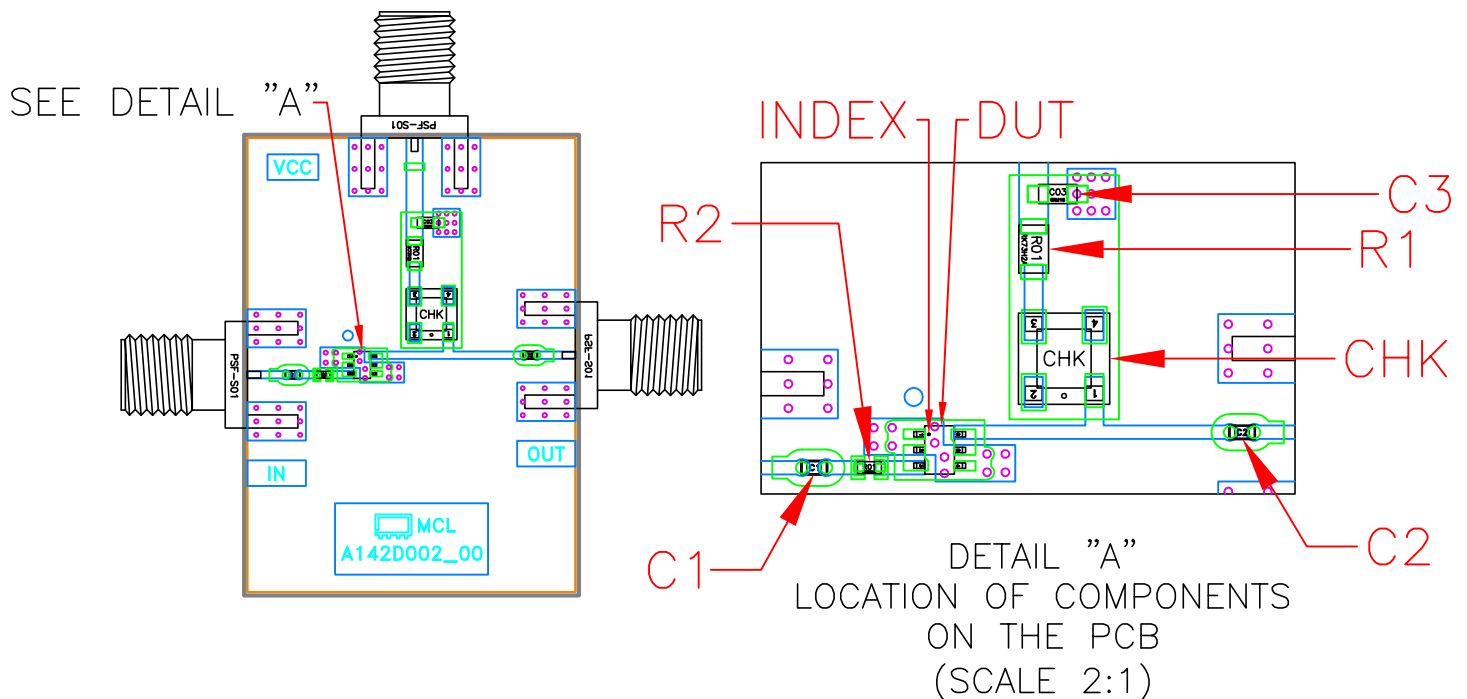

SCHEMATIC DIAGRAM

Component	Size	Description
C1,C2	0402	2400pF
C3	0603	0.1uF
R1	0805	36.5ohm
CHK		TCCH-80+
R2	0402	10ohm

Notes:

1. 50 Ohm SMA Female Connectors.
2. PCB Material: Roger R04350B or equivalent,
Dielectric constant=3.5, Thickness=0.010 inch

 **Mini-Circuits®**

All Mini-Circuits products are manufactured under exacting quality assurance and control standards, and are capable of meeting published specifications after being subjected to any or all of the following physical and environmental test.

Specification	Test/Inspection Condition	Reference/Spec
Operating Temperature	-45° to 85°C or -40° to 85°C Ambient Environment	Individual Model Data Sheet
Storage Temperature	-65° to 150° C Ambient Environment	Individual Model Data Sheet
Thermal Shock	-55° to 100°C, 100 cycles	MIL-STD-202, Method 107, Condition A-3, except +100°C
Mechanical Shock	1.5Kg, 0.5 ms, 5 shock pulses, Y1 direction only	MIL-STD-883, Method 2002, Condition B, except Y1 direction only
Vibration (Variable Frequency)	50g peak	MIL-STD-883, Method 2007, Condition B
Autoclave	15 psig, 100% RH, 121°C, 96 hours	JESD22-A102, Condition C
HAST	130°C, 85% RH, 96 hours	JESD22-A110
Solderability	10X Magnification	J-STD-002, Para 4.2.5, Test S, 95% Coverage
Solder Reflow Heat	Sn-Pb Eutetic Process: 240°C peak Pb-Free Process: 260°C peak	J-STD-020, Table 4-1, 4-2 and 5-2; Figure 5-1
Moisture Sensitivity: Level 1	Bake at 125°C for 24 hours Soak at 85°C/85% RH for 168 hours, Reflow 3 cycles at 260°C peak	J-STD-020
Marking Resistance to Solvents	Isopropyl alcohol + mineral spirits at 25°C; terpene defluxer at 25°C; distilled water + proylene glycol monomethyl ether +	MIL-STD-202, Method 215



All Mini-Circuits products are manufactured under exacting quality assurance and control standards, and are capable of meeting published specifications after being subjected to any or all of the following physical and environmental test.

Specification	Test/Inspection Condition	Reference/Spec
	monoethanolamine at 63°C to 70°C	