

# PRODUCT DATA SHEET

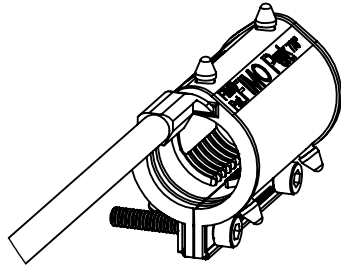
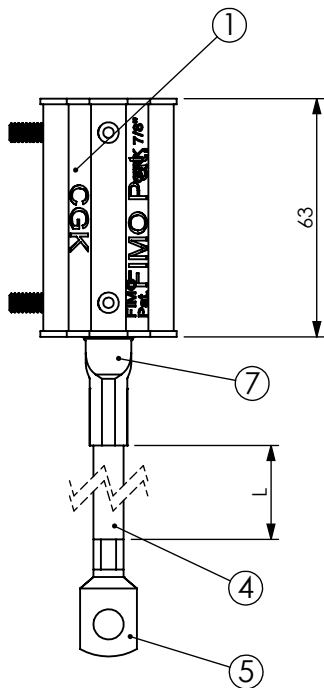
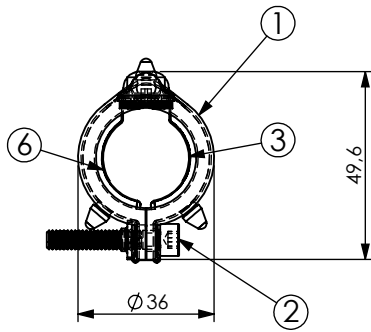

## A) SPECIFICATIONS

- 1 Shell: Stainless steel.
- 2 Hexagon socket head Screw: Stainless steel VCI 5x30
- 3 Gasket: Rubber EPDM.
- 4 16sqmm Connection cable: L=500 PE rigid copper cable.
- 5 Cable lug Ø8: Tinned copper.
- 6 Inner Contact: Tinned copper.
- 7 Contact bar: Tinned brass.

## B) RESISTANCE TESTS

### Waterproof test:

IP 68 (FIMO Test according to IEC60529 normative).

Environmental Resistance Test: IEC 68-2-14

Salt Fog Test: UNI 9227

Contact Resistance  $\leq 1\text{m}\Omega$

Operating Temperature  $-40^{\circ}\text{C} +85^{\circ}\text{C}$

## C) PACKAGING INFORMATION

Packing in boxes.

Label indicating:

product code, article, quantity,

production batch,



FIMO logo and figure.

( Customer code on request ).

## D) MOUNTING INSTRUCTIONS

IST 045

code	<b>6115090078</b>
article	CGK 7/8" M

<b>D</b>	<b>L</b>		
26-28	500	10	0.2212kg

RI	DATE	DR	DATE	AP	Description: Grounding Kit
02					
01					
00	17/12/2014	E.B.	17/12/2014	A.V.	
1 <sup>ST</sup> EMISSION					Use: Earthing of coaxial cables.
 Setting Installation Standards			