

# PRODUCT DATA SHEET

## A) SPECIFICATIONS

- 1 Tinned Brass contact bar
- 2 Butyl strip
- 3 Tin-plated copper mesh
- 4 Protecting and sealing self-agglomerating silicon tape. Color black on reel
- 5 Stainless Steel M8 connection screw
- 6 Stainless Steel grower washer
- 7 Rigid 7x1.70= 16mm<sup>2</sup> copper cable, black PE insulation
- 8 Cable lug Ø8: Tinned copper

## B) RESISTANCE TEST

### Lightning test:

Peak Current 100 kA (10/350 µs)

Charge 50C

Protection Level III-IV in accordance with IEC 61312-1 Standard

### Water Tightness:

IP 68 (FIMO Test in accordance with IEC60529)

### Corrosion Test:

Salt Spray test in accordance with ISO 9227 Standard

**Contact Resistance:** <math>\leq 1\text{ m}\Omega</math>

**Operating Temperature:** -50°C +80 °C

## C) DELIVERY MODALITIES

Packing in boxes ok 10 kits

Label indicanting:

product code, article, production, batch

FIMO logo and picture



(customer code on request)

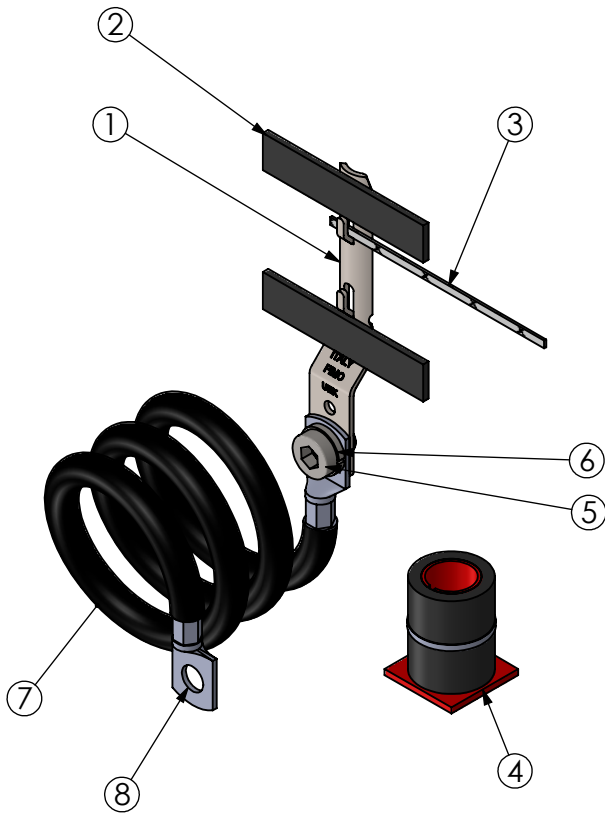

## D) MOUNTING INSTRUCTION

UEK IST 024 REV 0



code	<b>6115020001</b>
article	UEK 1

	
10	0.0725kg

RI	DATE	DR	DATE	AP	Description:  <b>UEK 1=universal earthing kit d. 5-11</b>
02					
01	14/03/2016	E.B.	14/03/2016	A.V.	
	Updating resistance test				
00	17/06/2014	E.B.	17/06/2014	A.V.	
1 <sup>ST</sup> EMISSION					
					Use: Earthing of coaxial cables and elliptic or rectangular waveguides Coaxial Cable : RG 223 - RG58 - RG59 - RG 8 - RG213/214 1/4"- 3/8" Elliptic guide : 220 - 380