

Evaluation Board and Circuit

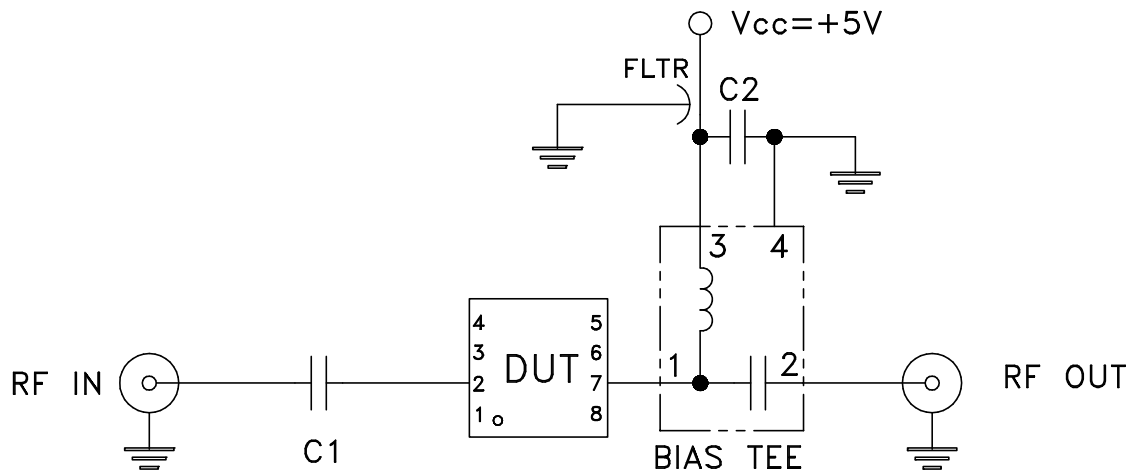
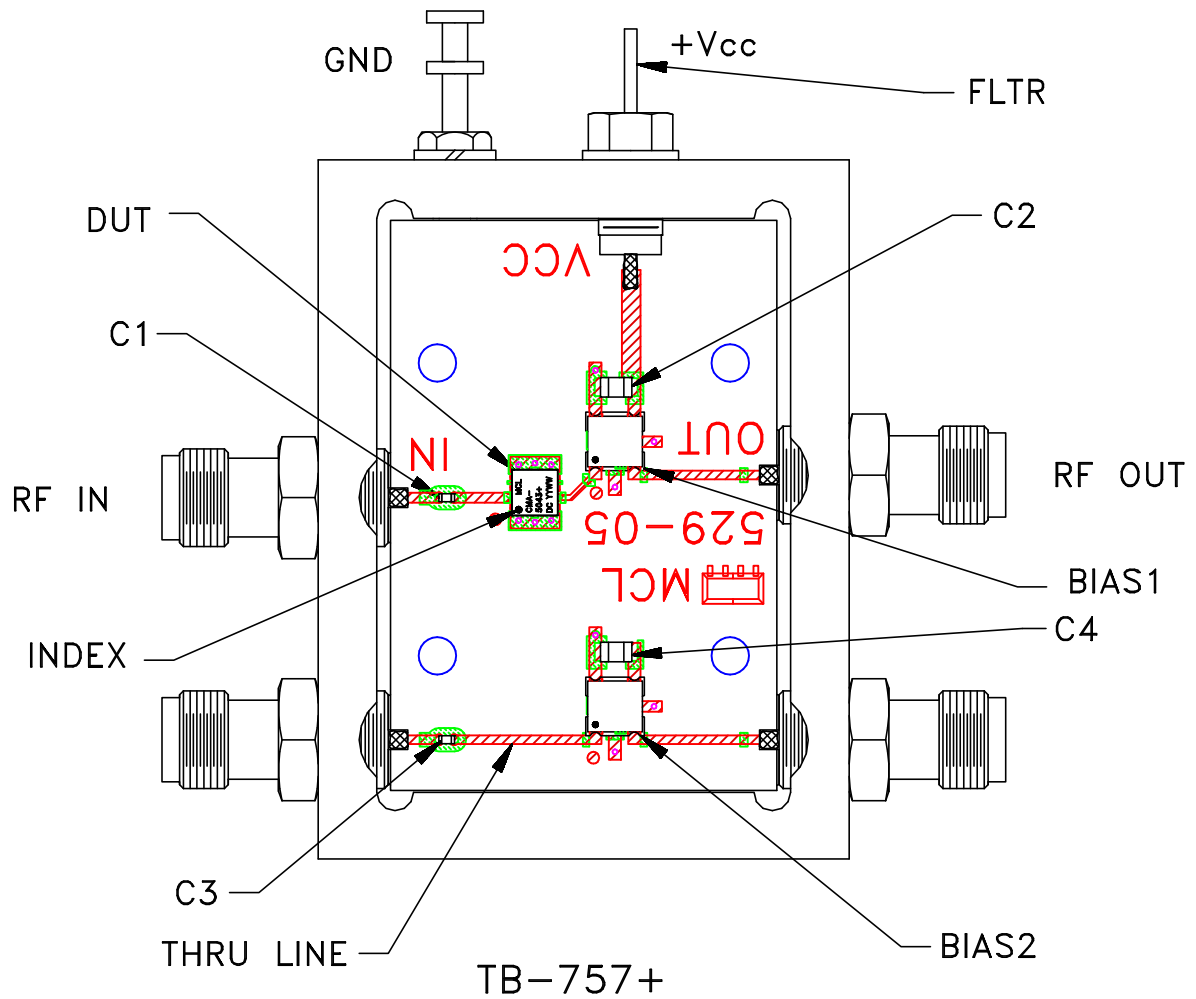

Schematic Diagram

Notes:

1. 50 Ohm SMA Female connectors.
2. PCB Material: R04350 or equivalent, Dielectric Constant=3.5, Thickness=.010 inch.

COMPONENT	VALUE
DUT	CMA-5043+
C1	1000 pF
C2	0.1 uF
FLTR	1500 pF
BIAS TEE	MCL BIAS-TEE TCBT-14+

 **Mini-Circuits®**